

Electromagnetic flowmeters

SITRANS F M MAG 5100 W

Operating Instructions • 11/2010



SITRANS F

SIEMENS

SIEMENS

SITRANS F

Electromagnetic Flowmeters SITRANS F M MAG 5100 W

Operating Instructions

<u>Introduction</u>	1
<u>Safety notes</u>	2
<u>Description</u>	3
<u>Installing/Mounting</u>	4
<u>Connecting</u>	5
<u>Service and maintenance</u>	6
<u>Troubleshooting/FAQs</u>	7
<u>Technical data</u>	8
<u>Appendix</u>	A

Electromagnetic sensor type SITRANS F M MAG
5100 W for use with transmitter types SITRANS F M
MAG 5000/6000/6000I

Legal information

Warning notice system

This manual contains notices you have to observe in order to ensure your personal safety, as well as to prevent damage to property. The notices referring to your personal safety are highlighted in the manual by a safety alert symbol, notices referring only to property damage have no safety alert symbol. These notices shown below are graded according to the degree of danger.

⚠ DANGER
indicates that death or severe personal injury will result if proper precautions are not taken.
⚠ WARNING
indicates that death or severe personal injury may result if proper precautions are not taken.
⚠ CAUTION
with a safety alert symbol, indicates that minor personal injury can result if proper precautions are not taken.
CAUTION
without a safety alert symbol, indicates that property damage can result if proper precautions are not taken.
NOTICE
indicates that an unintended result or situation can occur if the corresponding information is not taken into account.

If more than one degree of danger is present, the warning notice representing the highest degree of danger will be used. A notice warning of injury to persons with a safety alert symbol may also include a warning relating to property damage.

Qualified Personnel

The product/system described in this documentation may be operated only by **personnel qualified** for the specific task in accordance with the relevant documentation for the specific task, in particular its warning notices and safety instructions. Qualified personnel are those who, based on their training and experience, are capable of identifying risks and avoiding potential hazards when working with these products/systems.

Proper use of Siemens products

Note the following:

⚠ WARNING
Siemens products may only be used for the applications described in the catalog and in the relevant technical documentation. If products and components from other manufacturers are used, these must be recommended or approved by Siemens. Proper transport, storage, installation, assembly, commissioning, operation and maintenance are required to ensure that the products operate safely and without any problems. The permissible ambient conditions must be adhered to. The information in the relevant documentation must be observed.

Trademarks

All names identified by ® are registered trademarks of the Siemens AG. The remaining trademarks in this publication may be trademarks whose use by third parties for their own purposes could violate the rights of the owner.

Disclaimer of Liability

We have reviewed the contents of this publication to ensure consistency with the hardware and software described. Since variance cannot be precluded entirely, we cannot guarantee full consistency. However, the information in this publication is reviewed regularly and any necessary corrections are included in subsequent editions.

Table of contents

1	Introduction.....	5
1.1	Items supplied	5
1.2	History	5
1.3	Further Information	6
2	Safety notes.....	7
2.1	Laws and directives	7
2.2	Installation in hazardous area	9
2.3	Certificates	10
3	Description.....	11
3.1	System components	11
3.2	Theory of operation.....	12
4	Installing/Mounting.....	15
4.1	Installation safety precautions.....	15
4.2	Determining a location	16
4.3	Orienting the sensor.....	18
4.4	Mounting	19
4.5	Potential equalization.....	21
5	Connecting	23
5.1	Remote installation	24
5.2	Installation check	26
5.3	Potting	26
5.4	Direct burial.....	28
6	Service and maintenance	29
6.1	Maintenance.....	29
6.2	Recalibration	29
6.3	Transportation/storage.....	29
6.4	Unit repair.....	30
6.5	Technical support.....	30
6.6	Return procedures	31
7	Troubleshooting/FAQs.....	33
7.1	Sensor check	33
7.2	Fluctuating process values	35

8	Technical data	37
8.1	MAG 5100 W.....	37
8.2	Cable data	40
8.3	Effect of temperature on working pressure	41
8.4	Process fluid conductivity.....	42
8.5	Liner selection	43
8.6	Electrode selection.....	43
8.7	Sizing tables.....	44
8.8	Dimensions and weight.....	46
A	Appendix.....	51
A.1	Flange mating dimensions (metric).....	51
A.2	Factory settings.....	53
A.3	Coil resistance.....	55
A.4	Ordering	57
	Glossary	59
	Index.....	61

Introduction

These instructions contain all the information you need for using the device.

The instructions are aimed at persons mechanically installing the device, connecting it electronically, configuring the parameters and commissioning it as well as service and maintenance engineers.

Note

It is the responsibility of the customer that the instructions and directions provided in the manual are read, understood and followed by the relevant personnel before installing the device.

1.1 Items supplied

- SITRANS F M MAG 5100 W
- Calibration report
- SITRANS F M literature CD
- Quick Start guide

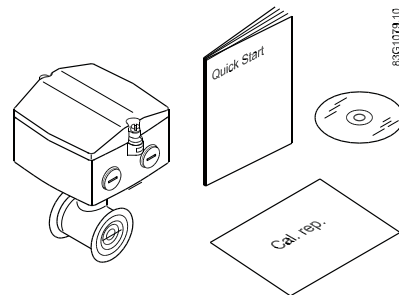

1.2 History

The contents of these instructions are regularly reviewed and corrections are included in subsequent editions. We welcome all suggestions for improvement.

The following table shows the most important changes in the documentation compared to each previous edition.

Edition	Remarks
11/2010	Minor updates
07/2010	First edition Replaces MAG 5100 W part of SITRANS F M Handbook (A5E02435647) and MAG 5100 W instruction (A5E00718677)

1.3 Further Information

The contents of these Operating Instructions shall not become part of or modify any prior or existing agreement, commitment or legal relationship. All obligations on the part of Siemens AG are contained in the respective sales contract which also contains the complete and solely applicable warranty conditions. Any statements contained herein do not create new warranties or modify the existing warranty.

Product information on the Internet

The Operating Instructions are available on the CD-ROM shipped with the device, and on the Internet on the Siemens homepage, where further information on the range of SITRANS F flowmeters may also be found:

Product information on the internet (<http://www.siemens.com/flowdocumentation>)

Worldwide contact person

If you need more information or have particular problems not covered sufficiently by the operating instructions, please get in touch with your contact person. You can find contact information for your local contact person on the Internet:

Local contact person (<http://www.automation.siemens.com/partner>)

See also

Technical support (Page 30)

 CAUTION
Correct, reliable operation of the product requires proper transport, storage, positioning and assembly as well as careful operation and maintenance. Only qualified personnel should install or operate this instrument.

Note

Alterations to the product, including opening or improper repairs of the product, are not permitted.

If this requirement is not observed, the CE mark and the manufacturer's warranty will expire.

2.1 Laws and directives

General requirements

Installation of the equipment must comply with national regulations.

Instrument safety standards

The device has been tested at the factory, based on the safety requirements. In order to maintain this condition over the expected life of the device the requirements described in these Operating Instructions must be observed.

CAUTION
Material compatibility Siemens Flow Instruments can provide assistance with the selection of wetted sensor parts. However, the full responsibility for the selection rests with the customer and Siemens Flow Instruments can take no responsibility for any failure due to material incompatibility.

CE marked equipment

All meters carry either a CE mark or a CE mark followed by eg.200

- CE200: This indicates that the product conforms to:
 - PED 97/23/EC
 - LVD 2006/95/EC
 - EMC 2004/108/EC
- CE: This indicates that the product conforms to:
 - LVD 2006/95/EC
 - EMC 2004/108/EC

Compliance with PED directive

"Pressure Equipment Directive" (PED) is mandatory for all pressure equipment sold within the EU and EFTA.

Siemens Flow Instruments products confirms to PED by following the tables below.

Table 2- 1 MAG 5100 W (7ME6580 only DN15 ... 600 (½" ... 24"))

Flange mm	PN 10	PN 16	PN 40	150 lb	300 lb
15	N/A	N/A	SEP	SEP	N/A
25	N/A	N/A	SEP	SEP	N/A
40	N/A	N/A	SEP	SEP	N/A
50	N/A	SEP	N/A	SEP	N/A
65	N/A	SEP	N/A	SEP	N/A
80	N/A	SEP	N/A	SEP	N/A
100	SEP	SEP	N/A	SEP	N/A
125	N/A	SEP	N/A	PED	N/A
150	N/A	PED	N/A	PED	N/A
200	SEP	PED	N/A	PED	N/A
250	LVD	PED	N/A	PED	N/A
300	LVD	PED	N/A	PED	N/A
350	LVD	PED	N/A	PED	N/A
400	LVD	PED	N/A	PED	N/A
450	LVD	PED	N/A	PED	N/A
500	LVD	PED	N/A	PED	N/A
600	LVD	PED	N/A	PED	N/A
700	LVD	PED*	N/A	N/A	PED
750	N/A	N/A	N/A	N/A	PED

800	LVD	PED*	N/A	N/A	PED
900	LVD	PED*	N/A	N/A	PED
1000	LVD	PED*	N/A	N/A	PED
1050	N/A	N/A	N/A	N/A	PED
1100	N/A	N/A	N/A	N/A	PED
1200	LVD	PED*	N/A	N/A	PED

The key to the tables is as follows:

PED	Product covered by PED and only available as fully PED-conforming
PED*	Product covered by PED but available as either conforming or non-conforming to PED
SEP	Excluded from PED under Sound Engineering Practice
LVD	Excluded from PED under the Low Voltage Directive





2.2 Installation in hazardous area

 WARNING
Equipment used in hazardous areas must be approved for use in hazardous area and marked accordingly. It is required that the special conditions for safe use provided in the manual and in the FM / CSA certificates are followed!

Hazardous area approvals

The device is approved for use in hazardous area and has the following approvals:

- MAG 5100 W DN 15 ... 1200: FM / CSA Class I, Div. 2

 WARNING
Make sure the hazardous area approval is suitable for the environment in which the device will be installed.
 WARNING
All approvals are based on non-flammable processes only!
 WARNING
Potential equalization In operation, the output is earthed through the conductive medium being measured and therefore potential equalisation is necessary throughout the hazardous area. The apparatus housing shall be connected to the potential equalising conductor in the hazardous area.
 WARNING
Laying of cables Cables for use in hazardous area must satisfy the requirements for having a proof voltage < AC 500 V applied between the conductor/ground, conductor/shield and shield/ground. Connect the devices that are operated in hazardous areas as per the stipulations applicable in the country of operation.

2.3 Certificates

Certificates are posted on the Internet and on the documentation CD-ROM shipped with the device.

See also

Technical data (Page 37)

Certificates on the Internet (<http://www.siemens.com/processinstrumentation/certificates>)

Description

The main applications of the SITRANS F M electromagnetic flow sensors can be found in the following fields:

- Process industry
- Chemical industry
- Steel industry
- Mining
- Utility
- Power generation & distribution
- Oil & gas / HPI
- Water & waste water
- Pulp & paper

3.1 System components

The SITRANS F M USM II flowmeter system includes:

- Transmitter (types: SITRANS F M MAG 5000/6000 or MAG 6000 I)
- Sensor (types: SITRANS F M MAG 1100/1100F, MAG 3100/3100 P or MAG 5100 W)
- Communication module (optional) (types: HART, PROFIBUS PA/DP, MODBUS RTU RS 485, Foundation Fieldbus H1, Devicenet)
- SENSORPROM memory unit

Communication solutions

The SITRANS F USM II range of add on modules, presently including HART, Foundation Fieldbus, MODBUS RTU RS 485, PROFIBUS PA / DP and Devicenet, are all applicable with the SITRANS F M MAG 6000 transmitter.

3.2 Theory of operation

The SITRANS F M MAG 5100 W sensor housing and flanges are designed in carbon steel and terminal box in fibre glass reinforced polyamide. Measuring pipe is made of stainless steel (AISI 304) and liners are available in NBR Hard Rubber, Ebonite Hard Rubber, or EPDM, which makes the sensor highly resistant to a wide range of chemicals. Electrodes are made of Hastelloy.



MAG 5100W DN15 ... 40



MAG 5100W DN50 ... 300



MAG 5100W DN350 ... 1200 (7ME6520)
MAG 5100W DN25 ... 2000 (7ME6580)



MAG 5100W compact installation with MAG 5000/6000 IP67



MAG 5100W compact installation with MAG 6000 I

The sensors carry a wide range of approvals, see Technical data (Page 37).

3.2 Theory of operation

The flow measuring principle is based on Faraday's law of electromagnetic induction.

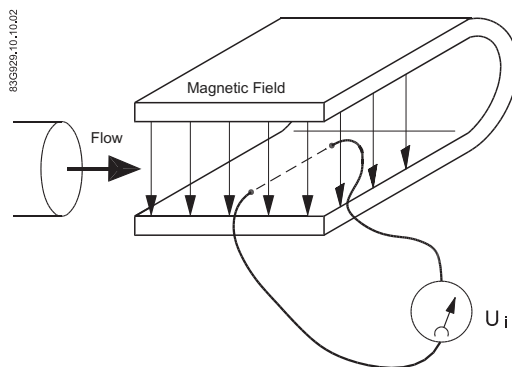

U_i = When an electrical conductor of length L is moved at velocity v , perpendicular to the lines of flux through a magnetic field of strength B , the voltage U_i is induced at the ends of the conductor

$$U_i = L \times B \times v$$

- U_i = Induced voltage
- L = Conductor length = Inner pipe diameter = k_1
- B = Magnetic field strength = k_2
- v = Velocity of conductor (media)
- $k = k_1 \times k_2$

$U_i = k \times v$, the electrode signal is directly proportional to the fluid velocity

Operating principle

The coil current module generates a pulsating magnetizing current that drives the coils in the sensor. The current is permanently monitored and corrected. Errors or cable faults are registered by the self-monitoring circuit.

Input circuit amplifies the flow-proportional induced voltage signal from the electrodes. The input impedance is extremely high: $>10^{14} \Omega$ which allows flow measurements on fluids with conductivities as low as $5 \mu\text{S}/\text{cm}$. Measuring errors due to cable capacitance are eliminated due to active cable screening.

Digital signal processor converts the analog flow signal to a digital signal and suppresses electrode noise through a digital filter. Inaccuracies in the transmitter as a result of long-term drift and temperature drift are monitored and continuously compensated for via the self-monitoring circuit. The analog to digital conversion takes place in an ultra low noise ASIC with 23 bit signal resolution. This has eliminated the need for range switching. The dynamic range of the transmitter is therefore unsurpassed with a turn down ratio of minimum 3000:1.

Description

3.2 Theory of operation

Installing/Mounting

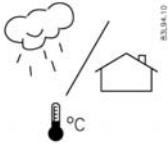

SITRANS F flowmeters with minimum IP67/NEMA 4X enclosure rating are suitable for in- and outdoor installations.

- Make sure that pressure and temperature specifications indicated on the device nameplate / label will not be exceeded.

WARNING

Installation in hazardous location

Special requirements apply to the location and interconnection of sensor and transmitter. See "Installation in hazardous area" (Page 9)

4.1 Installation safety precautions

WARNING

In applications with working pressures/media that can be dangerous to people, surroundings, equipment or others in case of pipe fracture, we recommend that special precautions such as special placement, shielding or installation of a security guard or a security valve are taken when the sensor is mounted.

- Ensure that stresses and loading caused by e.g. earthquakes, traffic, high winds and fire damage if appropriate are taken into account during installation.
- Ensure that the flowmeter is installed such that it does not act as a focus for pipeline stresses. External loadings are not taken into account in the flowmeter design.
- Provide adequate protection to minimise any risk of contact with hot surfaces.

WARNING

Prevent personal injuries by assuring that operation below pressure guards cannot take place, if working with vacuum or fluids boiling readily.

4.2 Determining a location

NOTICE
The sensor must always be completely filled with liquid.

- Locate the the flowmeter in u-shaped pipes if pipes are only partially filled or have free outlet

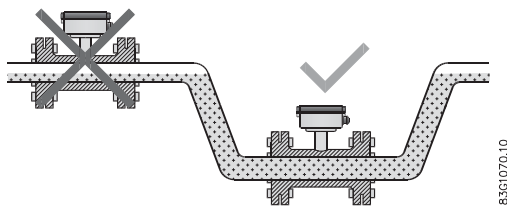

Figure 4-1 Correct installation in U-tube

- Avoid the following installations
 - Installation at the highest point in the pipe system
 - Installation in vertical pipes with free outlet

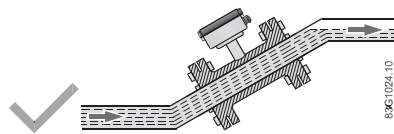

Figure 4-2 Correct installation with filled pipes

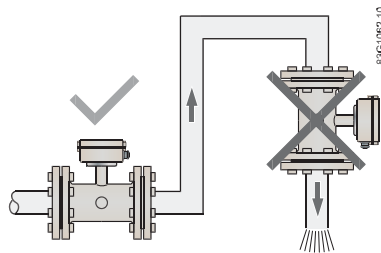

Figure 4-3 Correct installation at low point in system before outlet

Inlet and outlet conditions

To achieve accurate flow measurement it is essential to have straight lengths of inlet and outlet pipes and a certain distance to pumps and valves.

It is also important to centre the flowmeter in relation to pipe flanges and gaskets.

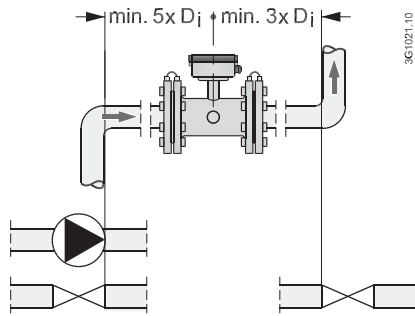
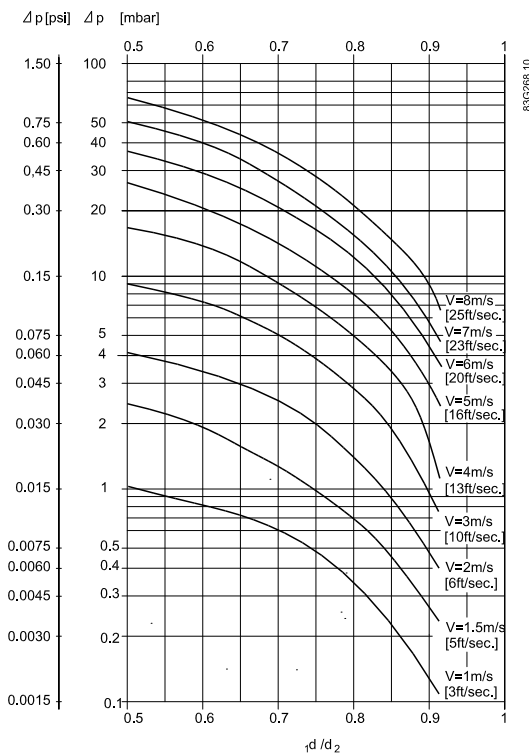
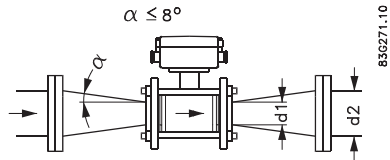

Figure 4-4 Inlet and outlet conditions

Installation in large pipes

The flowmeter can be installed between two reducers (e.g. DIN 28545). At 8° the following pressure drop curves apply. The curves are applicable to water.



Example:

A flow of 3 m/s (V) in a sensor with a diameter reduction from DN 100 to DN 80 ($d_1/d_2 = 0.8$) gives a pressure drop of 2.9 mbar.

4.3 Orienting the sensor

The sensor operates in all orientations, but Siemens has the following recommendations:

- Vertical installation with an upwards flow

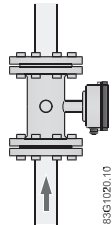

Figure 4-5 Vertical orientation, upwards flow

CAUTION

Abrasive liquids / liquids containing solid particles

A vertical installation minimizes wear and deposits in the sensor

NOTICE

Gas/air bubbles in the liquid

A vertical installation minimizes any negative effect of gas/air bubbles in the liquid

- Horizontal installation, terminal box upwards or downwards

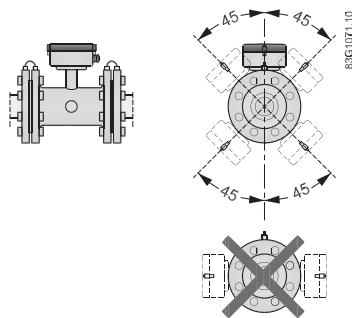

Figure 4-6 Horizontal installation, various terminal box positions

CAUTION

Do NOT mount the sensor with the terminal box sideways

This will position the electrodes at the top where there is possibility for air bubbles and at the bottom where there is possibility for mud, sludge, sand etc.

NOTICE

Empty pipe detection

For applications with empty pipe detection, the sensor can be tilted 45°, as shown above.

4.4 Mounting

- Install the sensor in rigid pipelines in order to support the weight of the meter.
- Center the connecting pipelines axially in order to avoid turbulent flow profiles.
- Use proper gaskets according to liner type

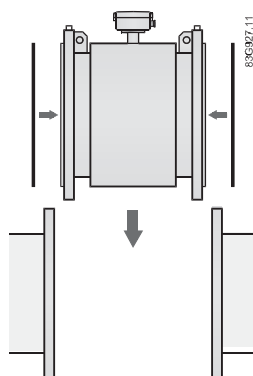

Figure 4-7 Correct installation with gaskets

Vibrations

Avoid strong vibrations.

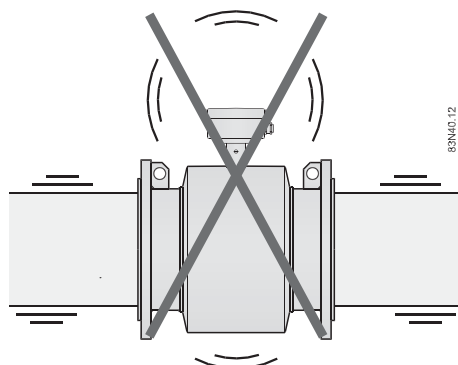

Figure 4-8 Avoid vibrations

CAUTION

In applications with strong vibrations, Siemens recommend remote mounting of the transmitter!

Torques

Fasten screws according to the torques values below

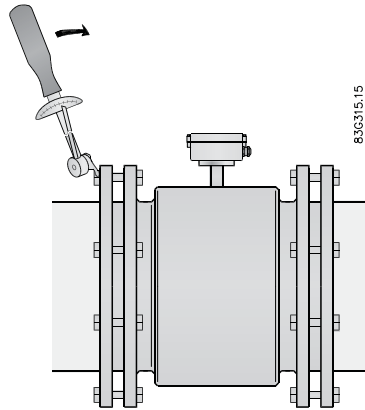

Figure 4-9 Torques values

NOTICE
Torque values are calculated on the basis of use of gaskets.

Table 4- 1 Maximum allowable torques

DN		PN 10		PN 16		PN 40		Class 150		AWWA	
Mm	Inch	Nm	F/lbs	Nm	F/lbs	Nm	F/lbs	Nm	F/lbs	Nm	F/lbs
15	½"	N/A	N/A	N/A	N/A	10	7	6	5	N/A	N/A
25	1"	N/A	N/A	N/A	N/A	10	7	7	5	N/A	N/A
40	1½"	N/A	N/A	N/A	N/A	16	12	9	7	N/A	N/A
50	2"	N/A	N/A	N/A	N/A	N/A	N/A	25	18	N/A	N/A
65	2½"	N/A	N/A	25/25	18/18	N/A	N/A	25	18	N/A	N/A
80	3"	N/A	N/A	25/25	18/18	N/A	N/A	34	25	N/A	N/A
100	4"	N/A	N/A	25/25	18/18	N/A	N/A	26	19	N/A	N/A
125	5"	N/A	N/A	29/32	21/24	N/A	N/A	42	31	N/A	N/A
150	6"	N/A	N/A	50/50	37/37	N/A	N/A	57	42	N/A	N/A
200	8"	50/50	37/37	50/52	37/38	N/A	N/A	88	65	N/A	N/A
250	10"	50/50	37/37	82/88	61/65	N/A	N/A	99	73	N/A	N/A
300	12"	57/62	42/46	111/117	82/86	N/A	N/A	132	97	N/A	N/A
350	14"	60/60	44/44	120/120	89/89	N/A	N/A	225	166	N/A	N/A
400	16"	88/88	65/65	170/170	125/125	N/A	N/A	210	155	N/A	N/A
450	18"	92/92	68/68	170/170	125/125	N/A	N/A	220	162	N/A	N/A
500	20"	103/103	76/76	230/230	170/170	N/A	N/A	200	148	N/A	N/A
600	24"	161/161	119/119	350/350	258/258	N/A	N/A	280	207	N/A	N/A
700	28"	200/200	148/148	304/304	224/224	N/A	N/A	N/A	N/A	200	148
750	30"	N/A	N/A	N/A	N/A	N/A	N/A	N/A	N/A	240	177

DN		PN 10		PN 16		PN 40		Class 150		AWWA	
800	32"	274/274	202/202	386/380	285/285	N/A	N/A	N/A	N/A	260	192
900	36"	288/288	213/213	408/408	301/301	N/A	N/A	N/A	N/A	240	177
1000	40"	382/382	282/282	546/546	403/403	N/A	N/A	N/A	N/A	280	207
1050	42"	N/A	N/A	N/A	N/A	N/A	N/A	N/A	N/A	280	207
1100	44"	N/A	N/A	N/A	N/A	N/A	N/A	N/A	N/A	290	214
1200	48"	395/395	292/292	731/731	539/538	N/A	N/A	N/A	N/A	310	229
1400	54"	-/503	-/317	-/736	-/543	N/A	N/A	N/A	N/A	528	389
1600	66"	-/684	-/505	-/913	-/674	N/A	N/A	N/A	N/A	698	515
1800	72"	-/771	-/569	-/937	-/692	N/A	N/A	N/A	N/A	700	516
2000	78"	-/867	-/640	-/1128	-/832	N/A	N/A	N/A	N/A	890	656

4.5 Potential equalization

To obtain optimum results from the measuring system, the sensor must have the same electrical potential as the liquid being measured.

This is achieved by means of built-in grounding electrodes.

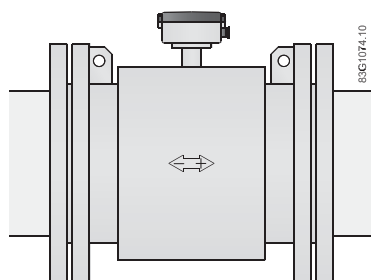

Figure 4-10 Potential equalization with earthing electrodes

Cathodic protected piping

Special attention must be paid to systems with cathodic protection

<p>⚠ WARNING</p> <p>Use in hazardous area!</p> <p>Cathodic pipe protection is not allowed in hazardous areas</p>
--

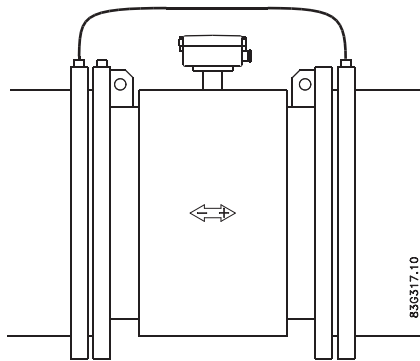

Figure 4-11 Cathodic protection

- Isolate the sensor from cathodic protected pipes using insulated bolts.
- Use bypass cable between the mating flanges

NOTICE

Remote mounted sensor versions

If the above is not acceptable, remote mounted sensors can alternatively be connected as follows:

- Connect coil current cable shield at sensor end via a 1.5 μ F condensator
- Make sure that electrode cable shield is not connected at both ends

The following contains a short description of how to connect a remote mounted sensor to a transmitter type SITRANS F M MAG 5000 / 6000 or MAG 6000 I. For more information, e.g. about wiring of power supply and outputs, refer to the Operating Instructions for the respective transmitters.

Before connecting

- Check that serial numbers on sensor and SENSORPROM® unit are identical.

 WARNING
The pertinent regulations must be observed for electrical installation. <ul style="list-style-type: none">• Never install the device with the mains voltage switched on!• Danger of electric shock!• The electrodes and magnetic current line may only be connected when the device is not connected to the power supply.• If the housing is under voltage (power supply), the cover may be unscrewed by qualified personnel only.

 WARNING
Mains supply from building installation Class II <p>A switch or circuit breaker (max. 15 A) must be installed in close proximity to the equipment and within easy reach of the operator. It must be marked as the disconnecting device for the equipment.</p>

Cable specifications

- Only use cables with at least the same degree of protection as the sensor to install the sensor.
- The line length from the cable gland to the terminals must be kept as short as possible. Line loops in the terminal box must be avoided.

- To guarantee the IP 67 degree of protection, use cables with the required specifications.

⚠ WARNING
Protective conductor terminal The required cable is min. AGW16 or 1.5 Cu.

⚠ WARNING
Wire insulation The insulation between the connected mains supply and 24 V AC/DC supply for the flowmeter must at least be rated with double or reinforced insulation at mains voltage. For field wiring installation: Ensure that the National Installation Code of the country in which the flowmeters are installed is met.

See also

Cable data (Page 40)

5.1 Remote installation

NOTICE
Remote installation only The following applies to remote installation of MAG 5000 / 6000 or MAG 6000 I.

1. Unscrew and remove terminal box lid.

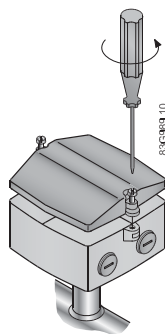

- Remove SENSORPROM® unit from sensor and mount it on connection plate in transmitter, see relevant transmitter operating instructions.

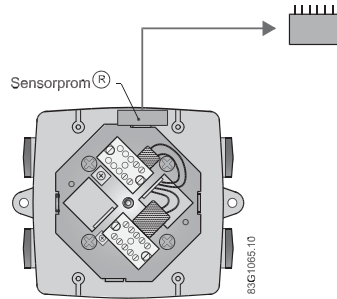

- Fit the ½" NPT or M20 cable glands for supply and output cables.
- Fit and connect electrode and coil cables as shown below.

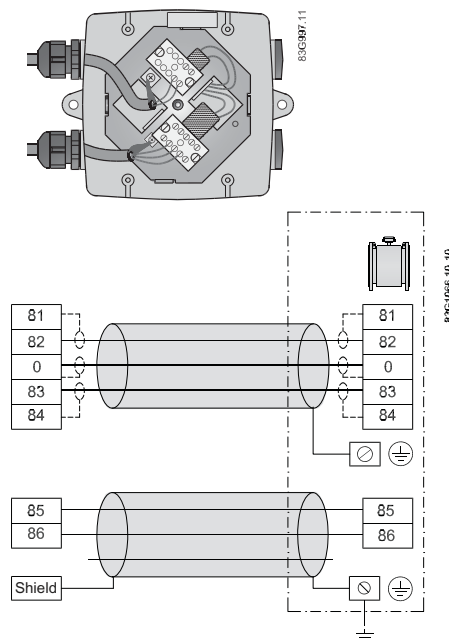

<p>⚠ CAUTION</p> <p>Unshielded cable ends</p> <p>Keep unshielded cable ends as short as possible.</p>
<p>⚠ CAUTION</p> <p>Prevent interference</p> <p>Separate electrode and coil cables to prevent interference.</p>

5. Tighten cable glands well to obtain optimum sealing.

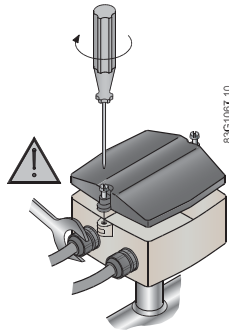

! WARNING
Mount terminal box lid before power up.

5.2 Installation check

The meter is now ready to go into normal operation - for commissioning and setting of parameters refer to the relevant transmitter manual.

Before commissioning it must be checked that:

- The device has been installed and connected in accordance with the guidelines provided in chapter 4 Installing/mounting (Page 15) and 5 Connecting (Page 23)

5.3 Potting

If sensor is buried or permanently submerged, terminal box must be encapsulated with silicon dielectric gel (non-toxic, transparent and self-healing gel)

CAUTION
Do not pot meter before electrical connections have been made.

- Mix the two components of the potting kit well and pour into terminal box.
- Let cure for approximately 24 hours at approximately 25°C (77°F). Curing time increases by 100% per -10°C (-18°F).

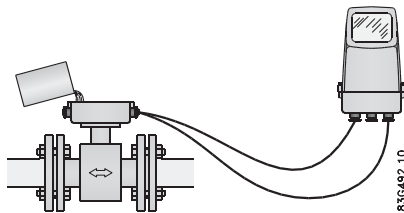

Horizontal orientation

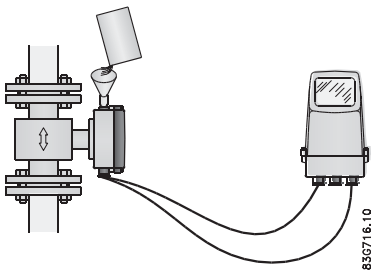

Vertical orientation

NOTICE
Gel can be penetrated with test instruments or be removed in case of cable replacement.

5.4 Direct burial

Recommendations for direct burial of remote sensor:

- Check for visible damages in paint finish !
- Use protection conduit !
- Protect sensor with pea gravel at least 3000 mm around sensor. This provides some drainage and also avoids caking sensor with earth. It also helps to locate sensor in case excavation takes place.

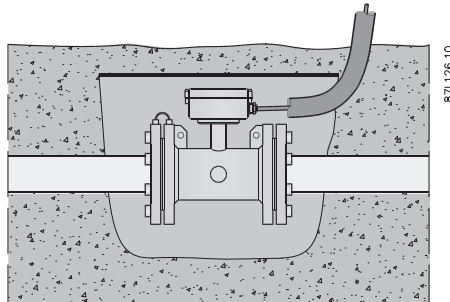

Figure 5-1 Direct burial of sensor

CAUTION

Sensor should not be subject to heavy vehicles applying excessive weight above sensor or pipeline

CAUTION

SENSORPROM® memory unit

Remove the SENSORPROM® from terminal box on sensor and relocate in remote transmitter prior to burying sensor.

All sensor data plate information and serial number should be recorded for each sensor prior to burying. This will ensure correct matching with SENSORPROM® unit.

WARNING

Electrical cable identification

Use suitable coil and electrode cables

Lay electrical cable identification tape above pea gravel before it is covered with earth.

Service and maintenance

6.1 Maintenance

The device is maintenance-free, however, a periodic inspection according pertinent directives and regulations must be carried out.

An inspection can include check of:

- Ambient conditions
- Seal integrity of the process connections, cable entries, and cover screws
- Reliability of power supply, lightning protection, and grounds

6.2 Recalibration

Siemens A/S Flow Instruments offers to recalibrate the sensor. The following calibrations are offered as standard:

- Standard matched pair calibration

Note

For recalibration the memory unit must always be returned with the sensor

6.3 Transportation/storage

The sensor is a fragile piece of equipment. Impact and shock can cause measuring inaccuracy. Therefore during transportation it must be placed in the transportation box delivered by Siemens Flow Instruments. If this is not possible, the alternative sensor packaging must be able to withstand the hazards from transportation.



Handling

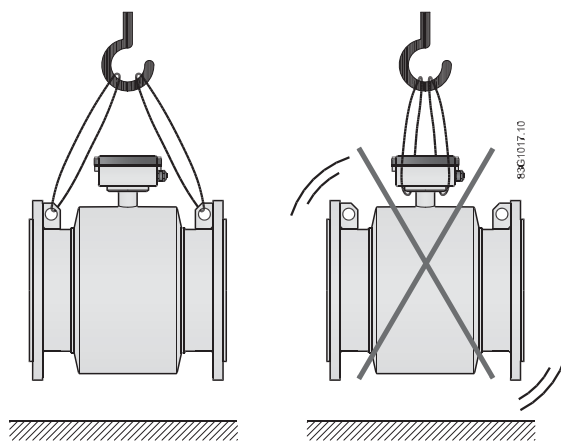

Figure 6-1 Handling of sensor

6.4 Unit repair

CAUTION
Repair and service must be carried out by Siemens authorized personnel only.

Note
Siemens Flow Instruments defines sensors as non-repairable products.

6.5 Technical support

If you have any technical questions about the device described in these Operating Instructions and do not find the right answers, you can contact Technical Support:

- Via the Internet using the **Support Request:**
Support request (<http://www.siemens.com/automation/support-request>)
- Via Phone:
 - Europe: +49 (0)911 895 7222
 - America: +1 423 262 5710
 - Asia-Pacific: +86 10 6475 7575

Further information about our technical support is available in the Internet at Technical support (<http://support.automation.siemens.com/WW/view/en/16604318>)

Service & Support on the Internet

In addition to our documentation, we offer a comprehensive knowledge base online on the Internet at:

Service and support (<http://www.siemens.com/automation/service&support>)

There you will find:

- The latest product information, FAQs, downloads, tips and tricks.
- Our newsletter, providing you with the latest information about your products.
- A Knowledge Manager to find the right documents for you.
- Our bulletin board, where users and specialists share their knowledge worldwide.
- You can find your local contact partner for Industry Automation and Drives Technologies in our partner database.
- Information about field service, repairs, spare parts and lots more under "Services."

Additional Support

Please contact your local Siemens representative and offices if you have additional questions about the device

Find your contact partner at:

Local contact person (<http://www.automation.siemens.com/partner>)

6.6 Return procedures

Enclose the delivery note, the cover note for return delivery together with the declaration of decontamination form on the outside of the package in a well-fastened clear document pouch.

Required forms

- **Delivery Note**
- **Cover Note for Return Delivery** with the following information
 - Cover note (<http://support.automation.siemens.com/WW/view/en/16604370>)
 - product (ordering number)
 - number of devices or spare parts returned
 - reason for the return

- **Declaration of Decontamination**

Declaration of Decontamination

(http://pia.khe.siemens.com/efiles/feldg/files/Service/declaration_of_decontamination_en.pdf)

With this declaration you certify *that the returned products/spare parts have been carefully cleaned and are free from any residues.*

If the device has been operated together with toxic, caustic, flammable or water-damaging products, clean the device before return by rinsing or neutralizing. Ensure that all cavities are free from dangerous substances. Then, double-check the device to ensure the cleaning is completed.

We shall not service a device or spare part unless the declaration of decontamination confirms proper decontamination of the device or spare part. Shipments without a declaration of decontamination shall be cleaned professionally at your expense before further proceeding.

You can find the forms on the Internet and on the CD delivered with the device.

Troubleshooting/FAQs

7.1 Sensor check

Requirement

To check the SITRANS F M sensors the following test instruments will be required:

- Digital Meter/Multimeter
- Megger
- (Moving Coil Meter)

Sensor check

Remove the transmitter from the sensor or remote position before making the following checks.

Coil resistance check

- Measure the coil resistance between connection numbers 85 and 86 using a digital meter.
Resistance should be around 100 ohms \pm 10 ohms. (See Coil resistance table)

A low reading may indicate moisture within the coil housing or shorted coil turns.

A high reading would indicate an open circuit coil.

NOTICE
In case of deviation from nominal coil values, the sensor is damaged and must be replaced

Coil insulation check

 WARNING
Potential hazard!
Only carry out a coil insulation check in non-hazardous area!

- Megger between connection number 85 and the sensor body.
The resistance should be above 20 Megohms.

A low megger reading would indicate the coil insulation is breaking down. This is normally due to fluid ingress into the coil housing.

Sensors with an insulation resistance down to 1 Megohms may still work satisfactorily but this is not guaranteed.

Electrode resistance check

- Measure the electrode resistance between connections 82 and Zero with a moving coil meter.
With a sensor full of fluid the resistance should be between 5Kohms and 50Kohms. If the sensor is empty the resistance will be infinite.
- Repeat the resistance measurements between connections 83 and Zero.
The results should be the same.

If the resistance is low there may be a short on the electrodes or wiring (in the case of a remote mounted transmitter). Alternatively there may be water ingress or moisture in the terminal box.

If the resistance is high and the pipe is completely full of fluid check the following:

1. The fluid is electrically conductive.
2. Electrodes are not coated with grease or any deposit.
3. Electrode circuit is not open
4. The remote mounted transmitter has a 3 core cable with an overall shield continuously from the sensor to the transmitter, including junction boxes and terminal rails inside panels.
5. The shield is connected to the Zero or to the earth terminal (PE) on the sensor.

NOTICE
Sensors removed from line
For sensors removed from line with dry bore, use megger between terminal 82 and compression plate, and 83 and compression plate to show any water ingress behind electrodes or within enclosure.

7.2 Fluctuating process values

Question

Why do the displayed process values fluctuate when the electrode cable is moved?

Answer

There are several causes to the fluctuating process values:

- Deposits on electrodes
 - Clean the electrodes.
- Defect electrode cable
 - Replace the cable
- Incorrect cable connection
 - Connect the electrode cable (82, 83, 0 and shield) according to the instructions in chapter Connecting (Page 23)

NOTICE
Vibrating environments It is recommended to use special low noise cables for sensor sizes DN 2 and 3 installed in vibrating environments.

Technical data

8.1 MAG 5100 W

Table 8- 1 Technical data

Version	MAG 5100W (7ME6520)	MAG 5100W (7ME6580)
Product characteristic	Mainly for the European market EPDM or NBR lining	Mainly for the non-European market Ebonite lining
Design and nominal size	<i>Coned sensor:</i> <ul style="list-style-type: none"> DN 15 ... 300 (½" ... 12") <i>Full bore sensor:</i> <ul style="list-style-type: none"> DN 350 ... 1200 (14" ... 48") 	<i>Full bore sensor:</i> <ul style="list-style-type: none"> DN 25 ... 2000 (1" ... 78")
Measuring principle	Electromagnetic induction	
Excitation frequency (Mains supply: 50 Hz/60 Hz)	<i>DN 15 ... 65 (½" ... 2½"):</i> <ul style="list-style-type: none"> 12.5 Hz / 15 Hz <i>DN 80 ... 150 (3" ... 6"):</i> <ul style="list-style-type: none"> 6.25 Hz / 7.5 Hz <i>DN 200 ... 300 (8" ... 12"):</i> <ul style="list-style-type: none"> 3.125 Hz / 3.75 Hz <i>DN 350 ... 1200 (14" ... 48"):</i> <ul style="list-style-type: none"> 1.5625 Hz / 1.875 Hz 	<i>DN 25 ... 65 (1" ... 2½"):</i> <ul style="list-style-type: none"> 12.5 Hz / 15 Hz <i>DN 80 ... 150 (3" ... 6"):</i> <ul style="list-style-type: none"> 6.25 Hz / 7.5 Hz <i>DN 200 ... 1200 (8" ... 48"):</i> <ul style="list-style-type: none"> 3.125 Hz / 3.75 Hz <i>DN 1400 ... 2000 (54" ... 78"):</i> <ul style="list-style-type: none"> 1.5625 Hz / 1.875 Hz

Table 8- 2 Process connections

Version	MAG 5100W (7ME6520)	MAG 5100W (7ME6580)
EN 1092-1	<i>PN 10 (145 psi):</i> <ul style="list-style-type: none"> DN 200 ... 300 (8" ... 12") Flat face flanges <i>PN 10 (145 psi):</i> <ul style="list-style-type: none"> DN 350 ... 1200 (14" ... 48") Raised face flanges <i>PN 16 (232 psi):</i> <ul style="list-style-type: none"> DN 50 ... 300 (2" ... 12") Flat face flanges <i>PN 16 (232 psi):</i> <ul style="list-style-type: none"> DN 350 ... 1200 (14" ... 48") Raised face flanges <i>PN 40 (580 psi):</i> <ul style="list-style-type: none"> DN 15 ... 40 (½" ... 1½") Flat face flanges 	Raised face (EN 1092-1, DIN 3501 and BS4504 have the same mating dimensions) PN 16 (87 psi): <ul style="list-style-type: none"> DN 1400 ... 2000 (54" ... 78") PN 10 (145 psi): <ul style="list-style-type: none"> DN 200 ... 2000 (8" ... 78") PN16 (232 psi): <ul style="list-style-type: none"> DN 65 ... 600 (2½" ... 24") PN 40 (580 psi): <ul style="list-style-type: none"> DN 25 ... 50 (1" ... 2")
ANSI B16.5	Class 150 lb: ½" ... 24"	Class 150 lb: 1" ... 24"

Technical data

8.1 MAG 5100 W

Version	MAG 5100W (7ME6520)	MAG 5100W (7ME6580)
AWWA C-207	Class D: • 28" ... 48", Flat face flanges	Class D: • 28" ... 78", Flat face flanges
AS4087	PN 16 (230 psi): • DN 50 ... 1200 (2" ... 48")	PN 16 (230 psi): • DN 50 ... 1200 (2" ... 48")
JIS B 2220:2004	-	K10 (1" ... 24")

Table 8- 3 Rated operating conditions

Version	MAG 5100W (7ME6520)	MAG 5100W (7ME6580)
Ambient temperature	-40 ... +70 °C (-40 ... +158 °F)	-40 ... +70 °C (-40 ... +158 °F)
• Sensor		
• With compact transmitter		
MAG 5000/6000	-20 ... +60 °C (-4 ... +140 °F)	-20 ... +60 °C (-4 ... +140 °F)
MAG 6000 I	-20 ... +60 °C (-4 ... +140 °F)	-20 ... +60 °C (-4 ... +140 °F)
Operating pressure [abs. bar] ¹	DN 15 ... 40 (½" ... 1½") 0.01 ... 40 bar (0.15 ... 580 psi) DN 50 ... 300 (2" ... 12") 0.03 ... 20 bar (0.44 ... 290 psi) DN 350 ... 1200 (14" ... 48") 0.01 ... 16 bar (0.15 ... 232 psi)	DN 25 ... 50 (1" ... 2") 0.01 ... 40 bar (0.15 ... 580 psi) DN 65 ... 1200 (2½" ... 48") 0.01 ... 16 bar (0.15 ... 232 psi) DN 1400 ... 2000 (54" ... 78") 0.01 ... 10 bar (0.15 ... 145 psi)
Enclosure rating		
Standard	IP67 to EN 60529 / NEMA 4X/6 (1 mH ₂ O for 30 minutes)	IP67 to EN 60529 / NEMA 4X/6 (1 mH ₂ O for 30 minutes)
Option	IP68 to EN 60529 / NEMA 6P (10 mH ₂ O continuously)	IP68 to EN 60529 / NEMA 6P (10 mH ₂ O continuously)
Corrosive category	C4 according to ISO 12944-2	C4 according to ISO 12944-2
Pressure drop	DN 15 and 25 (½" and 1"): • Max. 20 mbar (0.29 psi) at 1 m/s (3 ft/s) DN 40 ... 300 (1½" ... 12"): • Max. 25 mbar (0.36 psi) at 3 m/s (10ft/s) DN 350 ... 1200 (14" ... 48"): • Insignificant	Insignificant
Test pressure	1.5 x PN (where applicable)	1.5 x PN (where applicable)
Mechanical load (vibration)	18 ... 1000 Hz random in x,y, z directions for 2 hours according to EN 60068-2-36 Sensor: 3.17 grms Sensor with compact MAG 5000/6000 transmitter mounted: 3.17 grms Sensor with compact MAG 6000 I transmitter mounted: 1.14 grms	18 ... 1000 Hz random in x,y, z directions for 2 hours according to EN 60068-2-36 Sensor: 3.17 grms Sensor with compact MAG 5000/6000 transmitter mounted: 3.17 grms Sensor with compact MAG 6000 I transmitter mounted: 1.14 grms

Version	MAG 5100W (7ME6520)	MAG 5100W (7ME6580)
Process fluid temperature		
<i>NBR</i>	-10 ... +70 °C (14 ... 158 °F)	-
<i>EPDM</i>	-10 ... +70 °C (14 ... 158 °F)	-
<i>EPDM (MI-001)</i>	+0.1 ... +30 °C (32 ... 76 °C)	-
<i>Ebonite</i>	-	-10 ... +70 °C (14 ... 158 °F)
EMC	EMC 2004/108/EC	EMC 2004/108/EC

Maximum operating pressure decreases with increasing operating temperature

Table 8- 4 Design

Version	MAG 5100W (7ME6520)	MAG 5100W (7ME6580)
Housing and flange material	Carbon steel, with corrosion-resistant two-component epoxy coating (min. 150 µm) Corrosive category C4, according to ISO 12944-2	Carbon steel ASTM A 105, with corrosion-resistant two-component epoxy coating (min. 150 µm)
Measuring pipe	AISI 304 (1.4301)	AISI 304 (1.4301)
Electrodes	Hastelloy	Hastelloy
Grounding electrodes (standard	Hastelloy	Hastelloy
Terminal box	Fibre glass reinforced polyamide	Fibre glass reinforced polyamide

Table 8- 5 Certificates and approvals

Version	MAG 5100W (7ME6520)	MAG 5100W (7ME6580)
Calibration	DN 15 ... 300:	Zero-point, 2 x 25 % and 2 x 90 %
Standard production calibration, calibration report shipped with sensor	<ul style="list-style-type: none"> • Zero-point, 2 x 25 % and 2 x 90 % DN 350 ... 1200: <ul style="list-style-type: none"> • Zero-point, 1 x 25 % and 1 x 90 % 	
Custody transfer (only with MAG 5000/6000 CT)	<i>OIML R 49 pattern approval cold water (Denmark and Germany):</i> <ul style="list-style-type: none"> • DN 50 ... 300 (2" ... 12") <i>MI 001 cold water (EU):</i> <ul style="list-style-type: none"> • DN 50 ... 300 (2" ... 12") 	-



8.2 Cable data

Version	MAG 5100W (7ME6520)	MAG 5100W (7ME6580)
Drinking water approvals	<p><i>EPDM liner:</i></p> <ul style="list-style-type: none"> • ANSI/NSF 61 Standard (Cold water, US) • WRAS (WRc, BS6920 cold water, GB) • ACS (F) • DVGW W270 (D) • Belgaqua (NBR) <p><i>NBR liner:</i></p> <ul style="list-style-type: none"> • ANSI/NSF 61 Standard (Cold water, US), only ANSI and AWWA flanges) 	<ul style="list-style-type: none"> • NSF/ANSI Standard 61 (Cold water, US) • WRAS (WRc, BS6920 cold water, GB)
Other approvals	<ul style="list-style-type: none"> • MCERTS • PED - 97/23 EC¹⁾, CRN • FM Class 1, Div 2 • CSA Class 1, Div 2 	<ul style="list-style-type: none"> • PED - 97/23 EC¹⁾ (only < DN 600 (< 24")) • FM Class 1, Div 2 • CSA Class 1, Div 2

¹⁾ : For sizes larger than 600 mm (24") in PN 16, PED conformity is available as cost-added option. The basic unit will carry the LVD (Low Voltage Directive) and EMC approval.

8.2 Cable data

Description

Cable for standard electrode or coil	
Electrode cable, double shielded	
Cable kit with standard coil cable and electrode cable double shielded (also available as low noise cable for MAG 1100 sensor)	

Standard applications

Table 8- 6 Technical data, standard application cables

	Coil cable	Standard electrode cable
Basic data		
No. of conductors	2	3
Min. sqr. area	0.5 mm ²	0.2 mm ²
Shield	Yes	Yes
Max. capacitance	N/A	350 pF/m

	Coil cable	Standard electrode cable	
Max. cable loop resistance	Media temperature:		
	< 100 °C	40 Ω	N/A
	> 200 °C	6 Ω	N/A
Cable glands on sensor and transmitter	M20x1.5 gland - Cable ø 5 ... 13 mm (0.20 ... 0.51 inches)		
	½ NPT gland - cable ø 5 ... 9 mm (0.20 ... 0.35 inches)		

Special applications, e.g. low conductivity or electrical noise

Table 8- 7 Technical data, special application cables

	Coil cable	Special electrode cable	
Basic data	No. of conductors	3	3
	Sqr. area	1.5 mm ²	0.25 mm ²
	Shield	Yes	Double
	Color code	Brown, blue, black	Brown, blue, black
	Outside color	Grey	Grey
	Ext. diameter	7.8 mm	8.1 mm
	Conductor	Flexible CU	Flexible CU
	Isolation material	PVC	PVC
Ambient temperature	Flexible installation	-5 ... +70°C (23 ... 158°F)	-5 ... +70°C (23 ... 158°F)
	Non-flexible installtaion	-30 ... +70°C (-22 ... 158°F)	-30 ... +70°C (-22 ... 158°F)
Cable parameter	Capacity	161.50 pF/m	N/A
	Inductance	0.583 µH/m	N/A
	L/R	43.83 pH/Ω	N/A

8.3 Effect of temperature on working pressure

Effect of temperature on working pressure.

Table 8- 8 Metric measures (pressure in bar)

Flange specifications	Flange rating	Temperature (°C)			
		-5	10	50	90
Sizes DN25 ... 2000					
EN 1092-1	PN 10	10.0	10.0	9.7	9.4
	PN 16	16.0	16.0	15.5	15.1
	PN 40	40.0	40.0	38.7	37.7
ANSI B16.5	150 lb	19.7	19.7	19.3	18.0
AWWA C-207	Class D	10.3	10.3	10.3	10.3

8.4 Process fluid conductivity

Flange specifications	Flange rating	Temperature (°C)			
		-5	10	50	90
Sizes DN 15 ... 300 (order no. 7ME6520 only)					
EN 1092-1	PN 10	10.0	10.0	10.0	8.2
	PN 16	10.0	16.0	16.0	13.2
	PN 40	40.0	40.0	38.7	37.7
ANSI B16.5	150 lb	10.0	19.7	19.7	16.2

Table 8-9 Imperial measures (pressure in psi)

Flange specifications	Flange rating	Temperature (°F)			
		23	50	120	200
Sizes 1" ... 78"					
EN 1092-1	PN 10	145	145	141	136
	PN 16	232	232	225	219
	PN 40	580	580	561	547
ANSI B16.5	150 lb	286	286	280	261
AWWA C-207	Class D	150	150	150	150
Sizes ½" ... 12" (order no. 7ME6520 only)					
EN 1092-1	PN 10	145	145	145	119
	PN 16	145	232	232	191
ANSI B16.5	150 lb	145	286	286	235

8.4 Process fluid conductivity

Compact installation

Liquids with an electrical conductivity $\geq 5 \mu\text{S/cm}$.

Remote installation

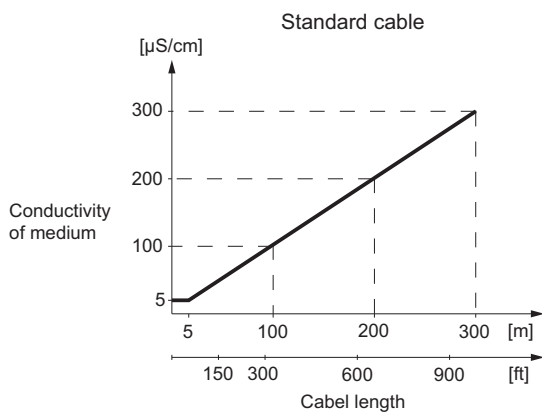

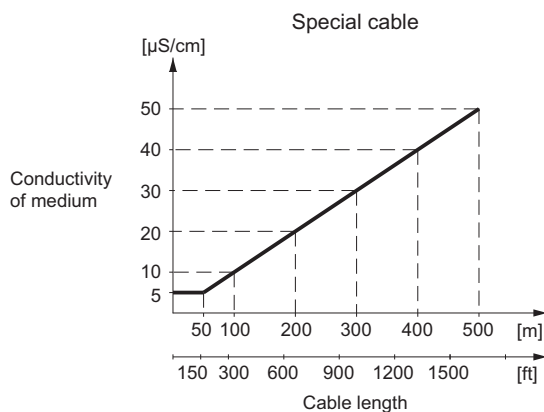

! WARNING

For detection of empty sensor the min. conductivity must always be >50 $\mu\text{S/cm}$ and the max. length of the electrode cable when remote mounted is 50 meters (164 ft). Special cable must be used!

For remote MID installations the max. cable length is 3 meters (9.8 ft). For other CT application standard requirements are applicable.

8.5 Liner selection

Liner	Applications
EPDM	Drinking water applications (not hydrocarbons)
Ebonite	Drinking water applications wastewater applications and certain chemicals applications
NBR	General purpose. Drinking water, sea waters

8.6 Electrode selection

Electrodes	
Hastelloy C	The preferred choice for water and wastewater, chemicals, food and beverage, and pharmaceutical industries

8.7 Sizing tables

Sizing table (DN 2 ... DN 2000)

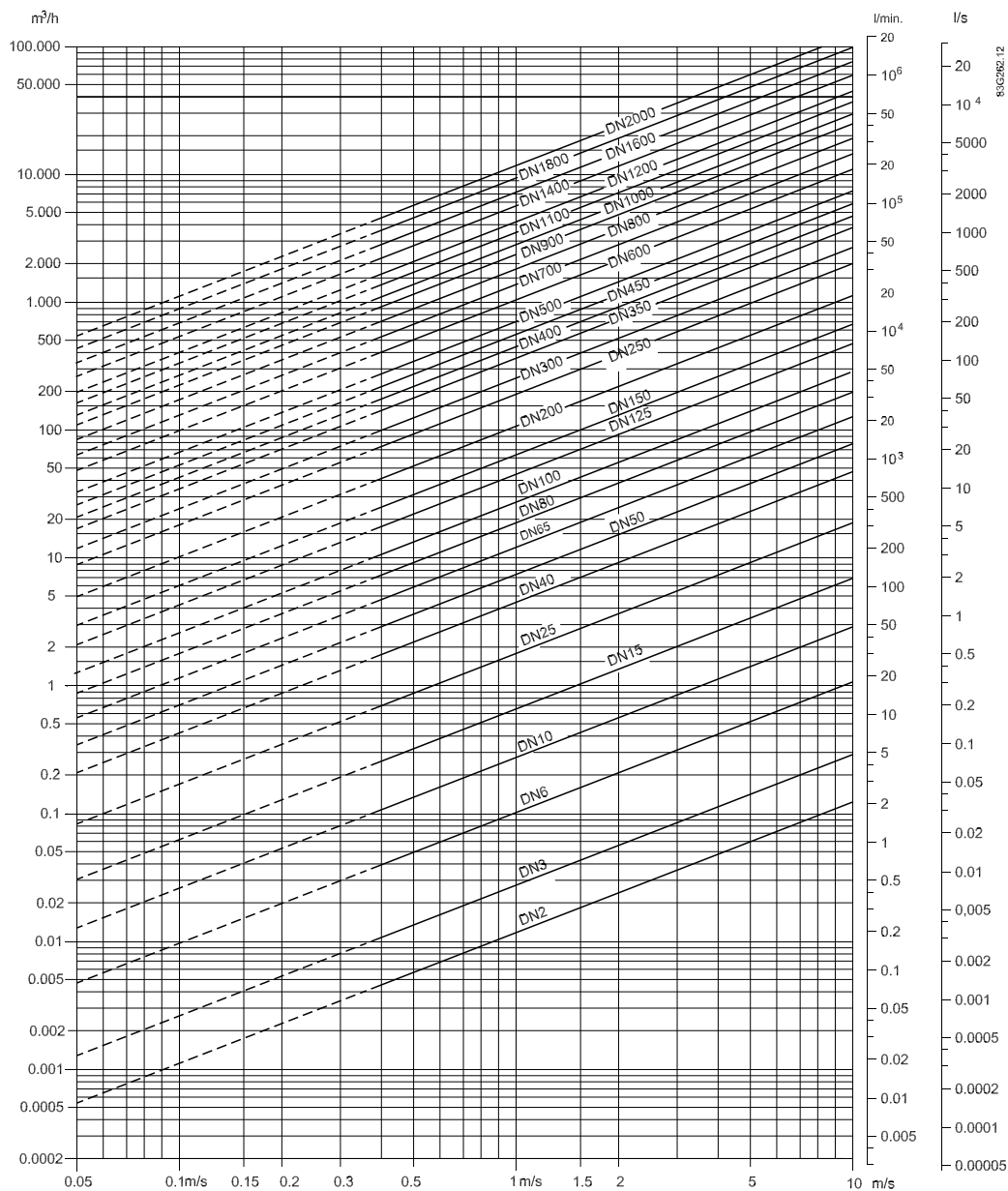

Sizing table (DN 1/12" ... DN 78")

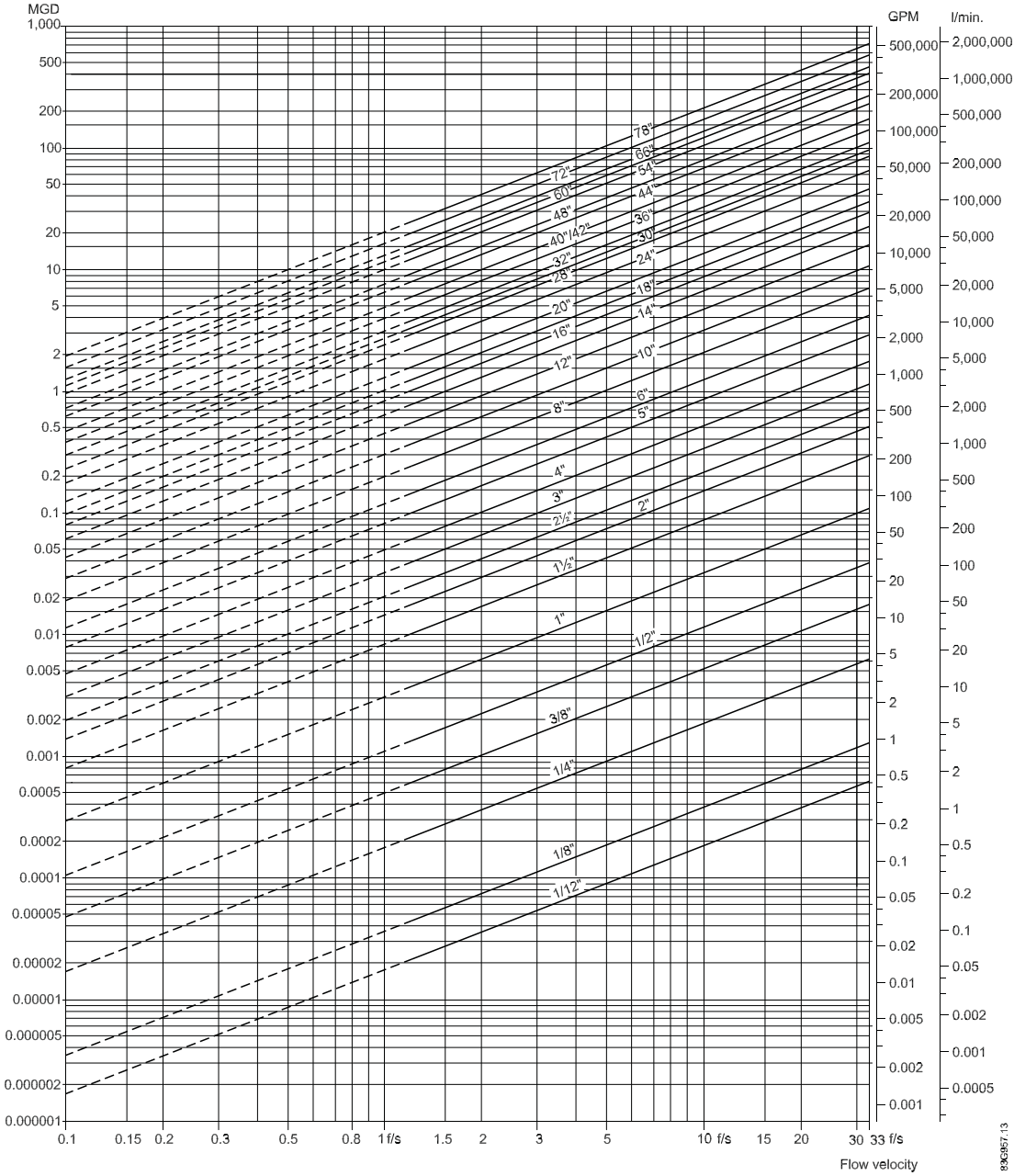

The tables show the relationship between flow velocity v, flow quantity Q and sensor dimension DN.

Guidelines for selection of sensor

Min. measuring range: 0 ... 0.25 m/s (0 ... 0.8 ft/s)

Max. measuring range: 0 ... 10 m/s (0 ... ft/s)

Normally the sensor size is selected so that the nominal flow velocity v lies within the measuring range 1 ... 3 m/s (1 ... 15 ft/s).

8.8 Dimensions and weight

Flow velocity calculation formula:

(metric measures)

$$V = \frac{1273.24 \times Q \text{ [l/s]}}{DN^2 \text{ [mm]}} \text{ [m/s]} \text{ or } V = \frac{353.68 \times Q \text{ [m}^3\text{/h]}}{DN^2 \text{ [mm]}} \text{ [m/s]}$$

(imperial measures)

$$V = \frac{0.408 \times Q \text{ [GPM]}}{(\text{Pipe ID})^2 \text{ [inch]}} \text{ [ft/s]} \text{ or } V = \frac{283.67 \times Q \text{ [MGD]}}{(\text{Pipe ID})^2 \text{ [inch]}} \text{ [ft/s]}$$

8.8 Dimensions and weight

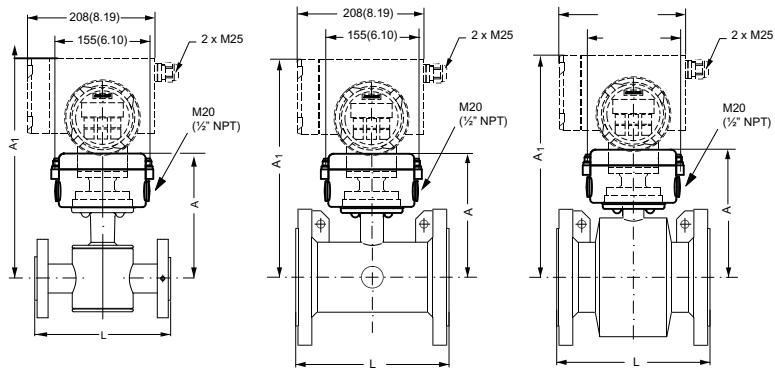

Figure 8-1 MAG 5100 W with MAG 6000 I / MAG 6000 I Ex d

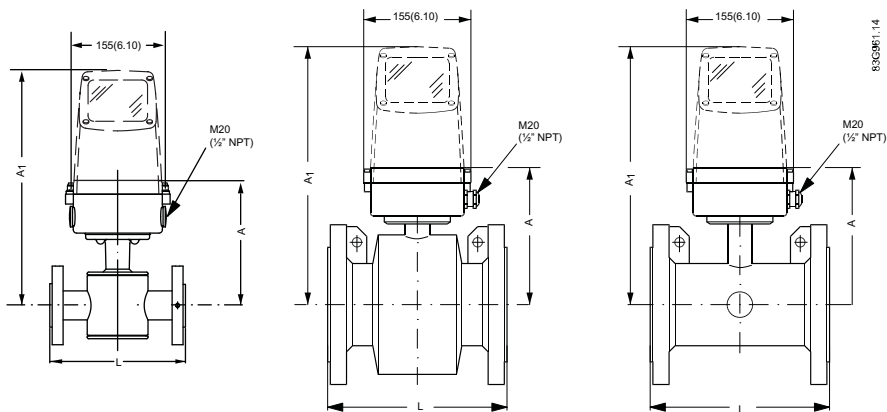

Figure 8-2 MAG 5100 W with MAG 5000 / 6000

Dimensions

Table 8- 10 Nominal size A

Nominal size		A			
		Order no. 7ME6520 NBR or EPDM liner		Order no. 7ME6580 Ebonite liner	
mm	inch	mm	inch	mm	inch
15	½	177	7	-	-
25	1	187	7.4	187	7.4
40	1½	202	8	197	7.8
50	2	188	7.4	205	8.1
65	2½	194	7.6	212	8.3
80	3	200	7.9	222	8.7
100	4	207	8.1	242	9.5
125	5	217	8.5	255	10.0
150	6	232	9.1	276	10.9
200	8	257	10.1	304	12.0
250	10	284	11.2	332	13.1
300	12	310	12.2	357	14.1
350	14	382	15.0	362	14.3
400	16	407	16.0	387	15.2
450	18	438	17.2	418	16.5
500	20	463	18.2	443	17.4
600	24	514	20.2	494	19.4
700	28	564	22.2	544	21.4
750	30	591	23.3	571	22.5
800	32	616	24.3	606	23.9
900	36	663	26.1	653	25.7
1000	40	714	28.1	704	27.7
1050	42	714	28.1	704	27.7
1100	44	765	30.1	755	29.7
1200	48	820	32.3	810	31.9
1400	54	N/A	N/A	925	36.4
1500	60	N/A	N/A	972	38.2
1600	66	N/A	N/A	1025	40.4
1800	72	N/A	N/A	1123	44.2
2000	78	N/A	N/A	1223	48.1

Technical data

8.8 Dimensions and weight

Table 8- 11 Nominal size L

Nominal size		L											
		PN 10		PN 16		PN 16 non-PED		PN 40		Class 150 AWWA		AS / JIS10K	
mm	inch	mm	inch	mm	inch	mm	inch	mm	inch	mm	inch	mm	inch
15	½	N/A	N/A	N/A	N/A	N/A	N/A	200	7.9	200	7.9	N/A	N/A
25	1	N/A	N/A	N/A	N/A	N/A	N/A	200	7.9	200	7.9	200	7.9
40	1½	N/A	N/A	N/A	N/A	N/A	N/A	200	7.9	200	7.9	200	7.9
50	2	N/A	N/A	200	7.9	N/A	N/A	N/A	N/A	200	7.9	200	7.9
65	2½	N/A	N/A	200	7.9	N/A	N/A	N/A	N/A	200	7.9	200	7.9
80	3	N/A	N/A	200	7.9	N/A	N/A	N/A	N/A	200	7.9	200	7.9
100	4	N/A	N/A	250	9.8	N/A	N/A	N/A	N/A	250	9.8	250	9.8
125	5	N/A	N/A	250	9.8	N/A	N/A	N/A	N/A	250	9.8	250 ¹⁾	9.8 ¹⁾
150	6	N/A	N/A	300	11.8	N/A	N/A	N/A	N/A	300	11.8	300	11.8
200	8	350	13.8	350	13.8	N/A	N/A	N/A	N/A	350	13.8	350	13.8
250	10	450	17.7	450	17.7	N/A	N/A	N/A	N/A	450	17.7	450	17.7
300	12	500	19.7	500	19.7	N/A	N/A	N/A	N/A	500	19.7	500	19.7
350	14	550	21.7	550	21.7	N/A	N/A	N/A	N/A	550	21.7	550	21.7
400	16	600	23.6	600	23.6	N/A	N/A	N/A	N/A	600	23.6	N/A	23.6
450	18	600	23.6	600	23.6	N/A	N/A	N/A	N/A	600	23.6	600	23.6
500	20	600	23.6	600	23.6	N/A	N/A	N/A	N/A	600	23.6	600	23.6
600	24	600	23.6	600	23.6	N/A	N/A	N/A	N/A	600	23.6	600	23.6
700	28	700	27.6	700	27.6	N/A	N/A	N/A	N/A	700	27.6	700 ²⁾	27.6 ²⁾
750	30	N/A	N/A	N/A	N/A	N/A	N/A	N/A	N/A	750	29.5	750 ²⁾	N/A
800	32	800	31.5	800	31.5	N/A	N/A	N/A	N/A	800	31.5	800 ²⁾	31.5 ²⁾
900	36	900	35.4	900	35.4	N/A	N/A	N/A	N/A	900	35.4	900 ²⁾	35.4 ²⁾
1000	40	1000	39.4	1000	39.4	N/A	N/A	N/A	N/A	1000	39.4	1000 ²⁾	39.4 ²⁾
1050	42	N/A	N/A	N/A	N/A	N/A	N/A	N/A	N/A	1000	39.4	N/A	N/A
1100	44	N/A	N/A	N/A	N/A	N/A	N/A	N/A	N/A	1100	43.3	N/A	N/A
1200	48	1200	47.2	1200	47.2	N/A	N/A	N/A	N/A	1200	47.2	1200 ²⁾	47.2 ²⁾
1400	54	1400	55.1	N/A	N/A	1400	55.1	N/A	N/A	1200	47.2	N/A	N/A
1500	60	1500	59.1	N/A	N/A	1500	59.1	N/A	N/A	1200	47.2	N/A	N/A
1600	66	1600	63.0	N/A	N/A	1600	63.0	N/A	N/A	1200	47.2	N/A	N/A
1800	72	1800	70.9	N/A	N/A	1800	70.9	N/A	N/A	1200	47.2	N/A	N/A
2000	78	2000	78.7	N/A	N/A	2000	78.7	N/A	N/A	1200	47.2	N/A	N/A

1) Not available with AS flange

2) Not available with JIS 10K flange

Weight

Table 8- 12 Weight

Nominal size		Order no. 7ME6520										Order no. 7ME6580	
		PN 10		PN 16		PN 40		Class 150 / AWWA		AS		PN / ANSI / AWWA / AS	
mm	inch	kg	lbs	kg	lbs	kg	lbs	kg	lbs	kg	lbs	kg	lbs
15	½	N/A	N/A	N/A	N/A	4	9	4	9	N/A	N/A	-	-
25	1	N/A	N/A	N/A	N/A	6	12	5	11	N/A	N/A	5	11
40	1½	N/A	N/A	N/A	N/A	8	18	7	15	N/A	N/A	8	17
50	2	N/A	N/A	9	20	N/A	N/A	8	20	N/A	N/A	9	20
65	2½	N/A	N/A	10.7	24	N/A	N/A	11	24	N/A	N/A	11	24
80	3	N/A	N/A	11.6	26	N/A	N/A	13	28	N/A	N/A	12	24
100	4	N/A	N/A	15.2	33	N/A	N/A	19	41	N/A	N/A	16	35
125	5	N/A	N/A	20.4	45	N/A	N/A	24	52	N/A	N/A	19	42
150	6	N/A	N/A	26	57	N/A	N/A	29	64	N/A	N/A	27	60
200	8	48	106	48	106	N/A	N/A	56	124	N/A	N/A	40	68
250	10	64	141	69	152	N/A	N/A	79	174	N/A	N/A	60	132
300	12	76	167	86	189	N/A	N/A	110	243	N/A	N/A	80	176
350	14	104	229	125	274	N/A	N/A	139	307	N/A	N/A	110	242
400	16	119	263	143	314	N/A	N/A	159	351	N/A	N/A	125	275
450	18	136	299	173	381	N/A	N/A	182	400	N/A	N/A	175	385
500	20	163	359	223	491	N/A	N/A	225	495	N/A	N/A	200	440
600	24	236	519	338	744	N/A	N/A	320	704	N/A	N/A	187	633
700	28	270	595	314	692	N/A	N/A	273	602	320	70	330	728
750	30	N/A	N/A	N/A	N/A	N/A	N/A	329	725	N/A	N/A	360	794
800	32	346	763	396	873	N/A	N/A	365	804	428	944	450	992
900	36	432	951	474	1043	N/A	N/A	495	1089	618	1362	53	1168
1000	40	513	1130	600	1321	N/A	N/A	583	1282	636	1399	66	1455
1050	42	N/A	N/A	N/A	N/A	N/A	N/A	687	1512	N/A	N/A	N/A	N/A
1100	44	N/A	N/A	N/A	N/A	N/A	N/A	763	1680	N/A	N/A	1140	2513
1200	48	643	1415	885	1948	N/A	N/A	861	1896	813	1789	1180	2601
1400	54	1592	3510	N/A	N/A	N/A	N/A	N/A	N/A	N/A	N/A	1600	3528
1500	60	N/A	N/A	N/A	N/A	N/A	N/A	N/A	N/A	N/A	N/A	2460	5423
1600	66	2110	4652	N/A	N/A	N/A	N/A	N/A	N/A	N/A	N/A	2525	5566
1800	72	2560	5644	N/A	N/A	N/A	N/A	N/A	N/A	N/A	N/A	2930	6460
2000	78	3640	8025	N/A	N/A	N/A	N/A	N/A	N/A	N/A	N/A	3665	8080

Appendix

A.1 Flange mating dimensions (metric)

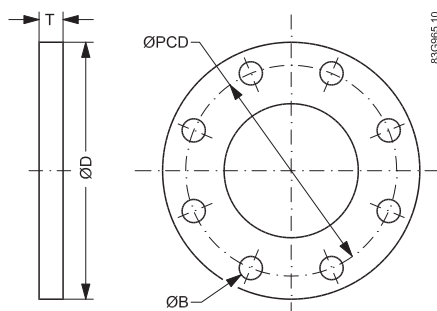

Figure A-1 Flange mating dimensions

Table A- 1 Flange mating dimensions (metric)

mm	Dimensions (mm)				Bolting	
	D	PCD	T	B	Holes	Bolts
PN10						
200	340	295	24	22	8	M20
250	395	350	26	22	12	M20
300	445	400	26	22	12	M20
350	505	460	28	22	16	M20
400	565	515	32	26	16	M24
450	615	565	36	26	20	M24
500	670	620	38	26	20	M24
600	780	725	42	3	20	M27
700	895	840	30	30	24	M27
800	1015	950	32	33	24	M30
900	1115	1050	34	33	28	M30
1000	1230	1160	34	36	28	M33
1200	1455	1380	38	39	32	M36
PN16						
50	165	125	19	18	4	M16
65	185	145	20	18	8	M16
80	200	160	20	18	8	M16
100	220	180	22	18	8	M16
125	250	210	22	18	8	M16
150	285	240	24	22	8	M20
200	340	295	26	22	12	M20
250	405	355	29	26	12	M24

Appendix

A.1 Flange mating dimensions (metric)

mm	Dimensions (mm)				Bolting	
	D	PCD	T	B	Holes	Bolts
300	460	410	32	26	12	M24
350	520	470	35	26	16	M24
400	580	525	38	30	16	M27
450	640	585	42	30	20	M27
500	715	650	46	33	20	M30
600	840	770	52	36	20	M33
700	910	840	36	36	24	M33
800	1025	950	38	39	24	M36
900	1125	1050	40	39	28	M36
1000	1255	1170	42	42	28	M39
1200	1485	1390	48	48	32	M45
PN40						
15	95	65	14	14	4	M12
25	115	85	16	14	4	M16
40	150	110	18	18	4	M16
150 lb						
15	89	60	12	16	4	M12
25	108	79	16	16	4	M16
40	127	98	18	16	4	M16
50	152	121	19	19	4	M16
65	178	140	22	19	4	M16
80	190	152	24	19	4	M16
100	229	191	24	19	8	M16
125	254	216	24	22	8	M20
150	279	241	25	22	8	M20
200	343	298	29	22	8	M20
250	406	362	30	25	12	M24
300	483	432	32	25	12	M24
350	533	476	35	28	12	M27
400	597	540	36.5	28	16	M27
450	635	578	40	32	16	M30
500	699	635	43	32	20	M30
600	813	749	48	35	20	M33

mm	Dimensions (mm)				Bolting	
	D	PCD	T	B	Holes	Bolts
AWWA						
700	927	864	33	35	28	M33
750	984	914	35	35	28	M33
800	1060	978	38	41	28	M39
900	1168	1068	41	41	32	M39
1000	1289	1200	41	41	36	M39
1050	1346	1257	44	41	36	M39
1200	1511	1422	48	41	44	M39

A.2 Factory settings

Dimension-dependent factory settings

Table A- 2 50 Hz version

DN		Fac settings	Qmax				Unit	Volume/pulse	Pulse unit	Totalizer unit
mm	Inch		Order no. 7ME6520		Order no. 7ME6580					
			Min.	Max.	Min.	Max.				
15	½	2000	159	6361	-	-	l/h	1	l	l
25	1	5000	441	17671	441	17671	l/h	10	l	l
40	1½	12	1.1	45	1.1	45	m³/h	10	l	l
50	2	20	1.7	63	1.7	70	m³/h	10	l	l
65	2½	30	2.9	100	2.9	119	m³/h	100	l	l
80	3	50	4.0	160	4.5	180	m³/h	100	l	l
100	4	120	6.2	250	7	282	m³/h	100	l	l
125	5	180	10.0	400	11	441	m³/h	100	l	m³
150	6	250	15.7	629	15.9	636	m³/h	100	l	m³
200	8	400	24.9	997	28.2	1130	m³/h	1	m³	m³
250	10	700	40.0	1600	44.1	1767	m³/h	1	m³	m³
300	12	1000	62.5	2500	63.6	2544	m³/h	1	m³	m³
350	14	1200	86.5	3463	86.5	3463	m³/h	1	m³	m³
400	16	1800	113	4523	113	4523	m³/h	1	m³	m³
450	18	2000	143.1	5725	143.1	5725	m³/h	1	m³	m³
500	20	3000	176.7	7068	176.7	7068	m³/h	1	m³	m³
600	24	4000	254.4	10178	254.4	10178	m³/h	10	m³	m³
700	28	5000	346.3	13854	346.3	13854	m³/h	10	m³	m³
750	30	6000	397.6	15904	397.6	15904	m³/h	10	m³	m³
800	32	7000	452.3	18095	452.3	18095	m³/h	10	m³	m³

Appendix

A.2 Factory settings

DN			Qmax				Unit	Volume/ pulse	Pulse unit	Totalizer unit
			Order no. 7ME6520		Order no. 7ME6580					
900	36	9000	572.5	22902	572.5	22902	m ³ /h	10	m ³	m ³
1000	40	12000	706.8	28274	706.8	28274	m ³ /h	10	m ³	m ³
1050	42	12000	706.8	28274	706.8	28274	m ³ /h	10	m ³	m ³
1100	44	14000	855.2	34211	855.2	34211	m ³ /h	10	m ³	m ³
1200	48	15000	1017.8	40715	1017.8	40715	m ³ /h	10	m ³	m ³
1400	54	25000	-	-	1385.4	55417	m ³ /h	10	m ³	m ³
1500	60	30000	-	-	1590.4	63617	m ³ /h	10	m ³	m ³
1600	66	35000	-	-	1809.5	72382	m ³ /h	10	m ³	m ³
1800	72	40000	-	-	2290.2	91608	m ³ /h	10	m ³	m ³
2000	78	45000	-	-	2827.4	113097	m ³ /h	10	m ³	m ³

Table A- 3 60 Hz version

DN			Qmax				Unit	Volume/ pulse	Pulse unit	Totalizer unit
			Order no. 7ME6520		Order no. 7ME6580					
mm	Inch	Fac. settings	Min.	Max.	Min.	Max.				
15	½	9	0.7	28	-	-	US GPM	1	US G	US G
25	1	22	1.9	77.8	1.9	77.8	US GPM	1	US G	US G
40	1½	52	4.9	199.1	4.9	199.1	US GPM	1	US G	US G
50	2	88	6.9	277.2	7.7	311.2	US GPM	1	US G	US G
65	2½	132	11.0	440.2	13.1	525.9	US GPM	1	US G	US G
80	3	220	17.6	705.1	19.9	796.7	US GPM	1	US G	US MG
100	4	528	27.5	1101	31.1	1244.8	US GPM	1	US G	US MG
125	5	793	44.0	1762.2	48.6	1945.1	US GPM	1	US G	US MG
150	6	1101	69.3	2772.9	70	2800.9	US GPM	1	US G	US MG
200	8	1761	109.7	4391.9	124.4	4979.5	US GPM	1	US G	US MG
250	10	3082	176.1	7045.2	194.5	7780.5	US GPM	1	US G	US MG
300	12	4402	275.1	11007.8	280	11203.9	US GPM	1	US G	US MG
350	14	5283	381.2	15249.7	381.2	15249.7	US GPM	1	US G	US MG
400	16	7925	497.9	19918.1	497.9	19918.1	US GPM	1	US G	US MG
450	18	8806	630.2	25208.8	630.2	25208.8	US GPM	1	US G	US MG
500	20	13209	778	31122	778	31122	US GPM	1	US G	US MG
600	24	17611	1120.3	44815.7	1120.3	44815.7	US GPM	10	US G	US MG
700	28	19812	1524.9	60999.1	1524.9	60999.1	US GPM	10	US G	US MG
750	30	22014	1750.6	70024.5	1750.6	70024.5	US GPM	10	US G	US MG
800	32	30820	1991.8	79672.4	1991.8	79672.4	US GPM	10	US G	US MG
900	36	39626	2522.8	100835.3	2522.8	100835.3	US GPM	10	US G	US MG
1000	40	52834	3112.2	124488.1	3112.2	124488.1	US GPM	10	US G	US MG
1050	42	52834	3431.2	137248.1	3431.2	137248.1	US GPM	10	US G	US MG
1100	44	61640	3765.7	150630.6	3765.7	150630.6	US GPM	10	US G	US MG

DN			Qmax				Unit	Volume/ pulse	Pulse unit	Totalizer unit
			Order no. 7ME6520		Order no. 7ME6580					
1200	48	66043	4481	179262.9	4481	179262.9	US GPM	10	US G	US MG
1400	54	110072	-	-	6099.9	243993.7	US GPM	1000	US G	US MG
1500	60	132086	-	-	7002.4	280098.3	US GPM	1000	US G	US MG
1600	66	154100	-	-	7967.2	318689.6	US GPM	1000	US G	US MG
1800	72	176115	-	-	10083.5	403341.5	US GPM	1000	US G	US MG
2000	78	198129	-	-	12448.8	497952.5	US GPM	1000	US G	US MG

A.3 Coil resistance

Table A- 4 Coil resistance

DN	Inch	MAG 1100, MAG 1100F		MAG 3100, MAG 3100P, MAG 5100 W (Order no. 7ME6580)		MAG 5100 W (Order no. 7ME6520)	
		Resistance	Tolerance	Resistance	Tolerance	Resistance	Tolerance
2	1/12	104 Ω	+/- 5	104			
3	1/8	104 Ω	+/- 5	104			
6	1/4	99 Ω	+/- 17	104			
10	3/8	99 Ω	+/- 17	104			
15 ¹⁾	1/2	91 Ω	+/- 9	104			
25	1	91 Ω	+/- 17	104	+/- 2	104	+/- 10
40	1 1/2	91 Ω	+/- 9	92	+/- 2	92	+/- 10
50	2	91 Ω	+/- 9	92	+/- 2	119.4	+/- 10
65	2 1/2	99 Ω	+/- 17	100	+/- 2	127	+/- 10
80	3	91 Ω	+/- 17	94	+/- 2	126	+/- 10
100	4	91 Ω	+/- 9	92	+/- 2	125	+/- 10
125	5	92	+/- 2	126	+/- 10		
150	6	94	+/- 2	116	+/- 10		
200	8	90	+/- 2	109	+/- 10		
250	10	92	+/- 2	104	+/- 10		
300	12	100	+/- 2	108	+/- 10		
350	14	112	+/- 2	100	+/- 6		
400	16	100	+/- 4	100	+/- 6		
450	18	108	+/- 4	100	+/- 6		
500	20	122	+/- 4	100	+/- 6		
600	24	115	+/- 4	98	+/- 6		
700	28	128	+/- 4	98	+/- 6		
750	30	133					
800	32	128	+/- 4	98	+/- 6		
900	36	131	+/- 4	98	+/- 6		



A.3 Coil resistance



		MAG 1100, MAG 1100F		MAG 3100, MAG 3100P, MAG 5100 W (Order no. 7ME6580)		MAG 5100 W (Order no. 7ME6520)	
1000	40	131	+/- 4	88	+/- 6		
1100	44	126					
1200	48	130	+/- 4	88	+/- 6		
1400	54	130					
1500	60	124					
1600	66	133					
1800	72	133					
2000	78	147					

1) On MAG 1100 DN 15 produced as from May 1999 the coil resistance must be 86 ohm, +/- 4 ohm.

NOTICE
Reference values
<ul style="list-style-type: none"> • All resistance values are at 20 °C • The resistance changes proportionally 0.4% / °C

Spare parts

Description	
Cable glands, 2 pcs. M20 ½" NPT	
Sealing screws for sensor/transmitter, 2 pcs.	
Terminal box, in polyamide, inclusive of lid M20 ½" NPT	

Description	
Terminal box lid, in polyamide	
Terminal box, in stainless steel, inclusive of lid M20 ½" NPT	
Potting kit for terminal box of MAG sensors for I P68/NEMA 6P (not for EX)	

A.4 Ordering

In order to ensure that the ordering data you are using is not outdated, the latest ordering data is always available on the Internet: Catalog process instrumentation (<http://www.siemens.com/processinstrumentation/catalogs>)

Glossary

ASIC

Application-Specific Integrated Circuit is an integrated circuit (IC) customized for a particular use, rather than intended for general-purpose use.

EMC

Electromagnetic compatibility (EMC) is the branch of electrical sciences which studies the unintentional generation, propagation and reception of electromagnetic energy with reference to the unwanted effects (Electromagnetic Interference, or EMI) that such energy may induce. The goal of EMC is the correct operation, in the same electromagnetic environment, of different equipment which use electromagnetic phenomena, and the avoidance of any interference effects.

IP

An IP (Ingress Protection) number is used to specify the environmental protection of enclosures around electronic equipment. These ratings are determined by specific tests. The IP number is composed of two numbers, the first referring to the protection against solid objects and the second against liquids. The higher the number, the better the protection. For example, in IP67 the first Number (6) means that the device is totally protected against dust, and the second (7) that it is protected against the effect of immersion between 15cm and 1m

PED

The Pressure Equipment Directive (97/23/EC) is the legislative framework on European level for equipment subject to a pressure hazard. It was adopted by the European Parliament and the European Council in May 1997 and has been obligatory throughout the European Union since May 2002.

SENSORPROM

All sensor related settings/data saved on an EPROM. SENSORPROM technology automatically configures the transmitter at start up providing calibration data, pipe size, sensor type, and output settings. The SENSORPROM automatically stores values or settings changed by users, and automatically re-programs any new transmitter without loss of accuracy.

USM

USM II is a Communication Platform. The Siemens USM II concept enables fitting of add-on bus modules without loss of functionality:

1. All modules can be fitted as true "plug & play"
2. Module and transmitter are automatically configured through the SENSORPROM

Index

A

Abrasive liquids, 18
Add-on modules, (See Communication module)
Applications, 11

C

Cable specifications, 24, 40
Cathodic protection, 21
Coil insulation check, 33
Coil resistance check, 33
Communication modules, 11
Compliance, 7
Contact person, 6
Customer Support Hotline, 30

D

Decontamination, 31
Dimensions, 47
Direct burial, 28
Document history, 5

E

Electrical connection
 Cable specifications, 24
 Remote installations, 24
 Safety instructions, 23
Electrode resistance check, 34
Empty pipe detection, 18

F

FAQ
 Fluctuating process values, 34
Flange mating dimensions, 51

G

Gas / Air bubbles, 18

H

Hazardous area
 Approvals, 10
Horizontal pipes
 Installation in, 18
Hotline, 30

I

Inlet / outlet conditions, 16
Installation
 in U-tube, 16
 Indoor/outdoor, 15
 Large pipes, 17
 Location in system, 16
 Mounting of sensor, 19
 Pipes with free outlet, 16
 Remote, 24
 Safety instructions, 15
Internet
 Contact person, 6, 31
 Flowdocumentation, 6
 Support, 31
Introduction, 5
Items supplied, 5

L

Laws and directives, 7

M

Mains supply, 23
Maintenance, 29
Material compatibility, 7
Measurement principle, 12
Mounting, (See Installation)

P

Potential equalization, 21
Potting, 27
Pressure
 Safety instructions, 15

Pressure Equipment Directive, 8
Process fluid
 Conductivity, 42
Protective conductor terminal, 24
Protective earth, 24

R

Recalibration, 29
Repair, 30
Return procedures, 31

S

Safety
 Instrument safety standards, 7
Safety instructions
 Electrical connection, 23
 Installation, 15
Safety notes, 7
Sensor check, 33
Sensor orientation, 18
Service, 30, 31
Support, 31
System components, 11

T

Theory of operation, 12
Torques values, 20
Transportation, 29

V

Vertical pipes
 Installation in, 18
Vibrations, 19

W

Weight, 49
Wire insulation, 24
Wiring, (See Electrical connection)

For more information

www.siemens.com/flow

Siemens A/S
Flow Instruments
DK-6430 Nordborg
Denmark

Subject to change without prior notice
Order No.: A5E03063678
Literature No.: A5E03063678-02
Copyright Siemens AG 11.2010
All rights reserved



* A 5 E 0 3 0 6 3 6 7 8 *

www.siemens.com/processautomation